

# Owner's Manual

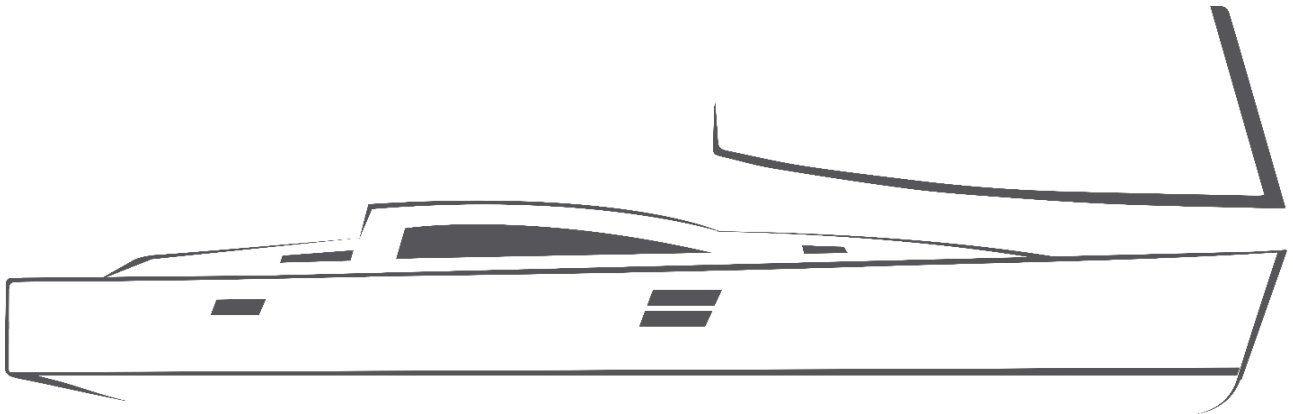

*elan* IMPRESSION 40.1

**Please keep this manual in a secure place and hand it over to the new owner when you sell the craft.**

If this is your first craft, or you are changing to a type of craft you are not familiar with, for your own comfort and safety, ensure that you obtain handling and operating experience before assuming command of the craft. Any boat dealer or national sailing federation or yacht club will be pleased to advise you of local sea schools, or competent instructors.

# CONTENTS

## Section

<b>WELCOME</b>	<b>1</b>
Boating Experience	1.1
Responsibility	1.2
<b>ABOUT THIS MANUAL</b>	<b>2</b>
Original Equipment Manufacturer (OEM) Manuals	2.1
Safety Labels	2.2
Explanation of Hazard Warnings	2.3
<b>GENERAL ARRANGEMENT</b>	<b>3</b>
Boat Identification & CE Marking Classification	3.1
RCD Design Category Explanation	3.1.1
Principal Dimensions	3.2
Hull Size	3.2.1
Maximum Recommended Power	3.2.2
Weights	3.2.3
Fixed Tanks	3.2.4
<b>SYSTEMS DESCRIPTIONS</b>	<b>4</b>
Bilge Pumps	4.1
Electrical System	4.2
DC System	4.2.1
AC System	4.2.2
Control panel	4.2.3
Fuel System	4.3
Gas System	4.4
Procedure for Changing Gas Cylinder	4.4.1
Inspection of Gas System	4.4.2
Steering System	4.5
Emergency Steering arrangements	4.5.1
Black Water System	4.6
Thrusters	4.7
Anchor Windlass	4.8
<b>PRE-LAUNCH OBSERVATIONS</b>	<b>5</b>
Recommended Safety Equipment	5.1
Risk of Loss of Stability	5.2
Risk of Flooding	5.3
Through Hull Fittings including Seacocks	5.3.1
Strainers	5.3.2
Risk of Fire	5.4
Fire Fighting Equipment	5.4.1
Fire Escapes	5.4.2

Risk of Falling Overboard	5.5
Liferaft stowage	5.6

**NAVIGATION & OPERATION** **6**

---

Use of Engines	6.1
Handling Characteristics	6.2
Visibility from the Main Steering Position	6.3
Navigation Lights	6.4
Anchoring, Mooring & Towing	6.5
Filling With Fuel	6.6

**MAINTENANCE** **7**

---

Maintaining the Electrical System	7.1
Winter Storage	7.2

**ENVIRONMENTAL AWARENESS** **8**

---

Leakage of Petrochemicals	8.1
Black & Grey Water	8.2
Household Waste	8.3
Noise	8.4
Wash / Waves	8.5

# 1 WELCOME

Congratulations on becoming the new owner of a: Elan Impression i40.1

Make sure you receive a full explanation of all systems from the person transferring ownership to you.

## 1.1 Boating Experience

If this is your first craft, or you are changing to a type of craft you are not familiar with, for your own comfort and safety, ensure that you obtain handling and operating experience before assuming command of the craft.

Any boat dealer or national sailing federation or yacht club will be pleased to advise you of local sea schools, or competent instructors

Regardless of the craft's seaworthiness and its certified design category, protection from freak sea and wind conditions cannot be guaranteed. Beware of offshore winds and currents. The ability, experience and fitness of the crew, therefore, should be taken into consideration before making any voyage.

## 1.2 Responsibility

It is the boat owner/operator's responsibility to:

- 1 Know the limitations of your boat;
- 2 Follow the rules of the road;
- 3 Keep a sharp lookout for people and objects in the water;
- 4 Ensure that the anticipated wind and sea conditions will correspond to the design category of your boat and that you and your crew are able to handle the boat in these conditions;
- 5 Never sail when the operator is under the influence of drugs or alcohol;
- 6 Be aware of the crew/passenger's safety at all times;
- 7 Ensure all crew receive suitable training, particularly with regards to location and operation of safety equipment;
- 8 Reduce speed when there is limited visibility, rough water, people in the water nearby, boats, or structures;
- 9 Ensure the craft is properly maintained at all time;
- 10 Have the craft inspected by qualified personnel at regular intervals and whenever a cause for concern is raised; and
- 11 Ensure compliance with all legislation in place in the area of operation. These may include requirements for the carriage of life saving equipment, licensing of the helmsman and respect for the environment.

## 2 ABOUT THIS MANUAL

This manual has been compiled to help you to operate your craft with safety and pleasure. It contains details of the craft; the equipment supplied or fitted its systems and information on their operation. Please read it carefully and familiarise yourself with the craft before using it. Ensure that everyone who will operate the vessel reads this manual before setting out.

This manual complies with the EU Recreational Craft Directive (RCD) and should not be perceived as an exhaustive guide to the vessel. A manual is not a replacement for experience and common sense!

### 2.1 Original Equipment Manufacturer (OEM) Manuals





This manual includes important fundamentals regarding equipment supplied by other manufacturers. More detailed information regarding such equipment can be found in manuals provided by the OEM.



A list of these manuals is given here:

- Engine
- Steering gear
- Generator
- Inverter
- Navigation lights
- Batteries
- Water heater
- Instruments
- Blowers
- Windlass
- Battery charger/monitor
- Window wipers
- VHF radio
- Fridge / freezer
- Stereo components





## 2.2 Safety Labels

The craft and this manual show symbols which advise the owner/operator and crew of imperative safety precautions to follow when operating and/or servicing equipment. The following symbols may be found on your craft. They should be respected at all times.

	Hazard - usually followed by text description (see following section)
	Electrical Hazard
	Fire Hazard
	Location of fire extinguisher
	Escape

	Read the Owners Manual
	Fuel fill point: letter 'D' denotes suitability for 'diesel fuel'
	Sling position for safe lifting of the vessel
<b>FIRE PORT</b>	Dedicated discharge opening for extinguisher

## 2.3 Explanation of Hazard Warnings

	Danger	Denotes an extreme intrinsic hazard exists which would result in high probability of death or irreparable injury if proper precautions are not taken.
	Warning	Denotes a hazard exists which can result in injury or death if proper precautions are not taken.
	Caution	Denotes a reminder of safety practices or directs attention to unsafe practices which could result in personal injury or damage to the craft or components.
	Information	Denotes useful or important facts or suggestions that can greatly enhance safety and efficiency of operations.
	Caution	Do not remove or obstruct any safety label. Replace any label which becomes illegible.

### 3 GENERAL ARRANGEMENT

#### Layout option 3 cabins

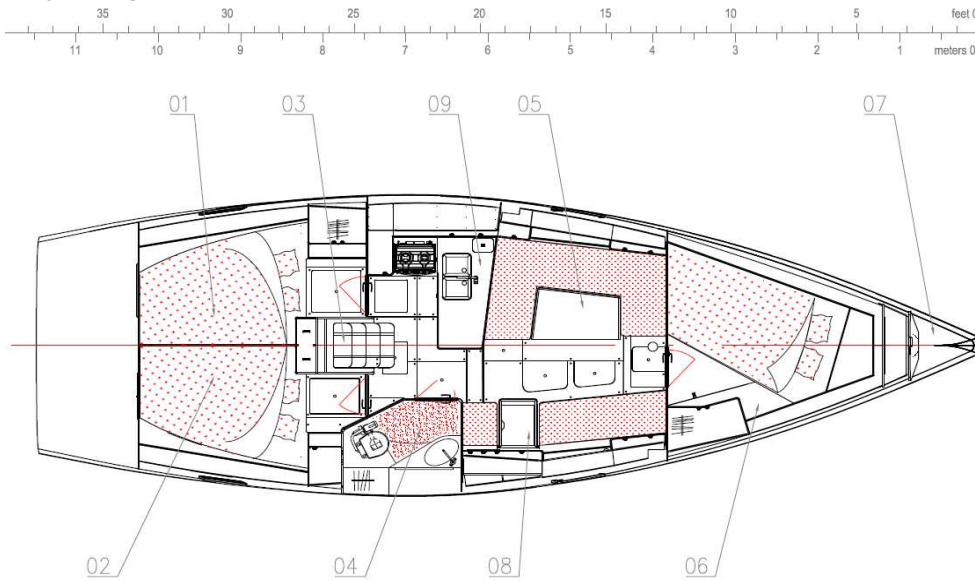

- |                                      |                    |
|--------------------------------------|--------------------|
| 01 Aft cabin – Port side             | 06 Forward cabin   |
| 02 Aft cabin – Starboard side        | 07 Anchor locker   |
| 03 Companionway – Engine compartment | 08 Navigation area |
| 04 Head / Shower                     | 09 Galley          |
| 05 Saloon                            |                    |

#### Layout options 2 cabins

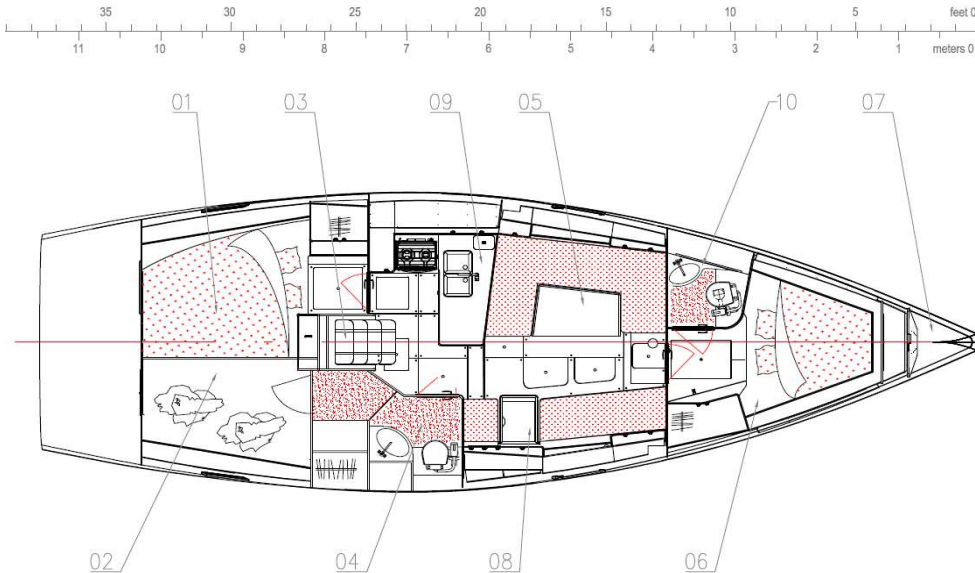

- |                                      |                        |
|--------------------------------------|------------------------|
| 01 Aft cabin – Port side             | 06 Forward cabin       |
| 02 Aft cabin – Starboard side        | 07 Anchor locker       |
| 03 Companionway – Engine compartment | 08 Navigation area     |
| 04 Head / Shower                     | 09 Galley              |
| 05 Saloon                            | 10 Head / Shower - FWD |

### 3.1 Boat Identification & CE Marking Classification

Type of Boat	Elan Impression i40.1				
Manufacturer's Craft Identification Number	SI-ELA40111J920				
Name of Boat Manufacturer	Elan d.o.o.				
RCD Design Category		A	B	C	D
Maximum recommended number of people	adults	11			
	child	0			

1 RCD = EU Recreational Craft Directive (2013/53/EU)

2 See table in section

3 For maximum weight limit see: 3.2.3

#### 3.1.1 RCD Design Category Explanation

This vessel carries the CE marking (shown here) to indicate that it complies with the EU Recreational Craft Directive. It has been assigned the Design Category explained below:



A recreational craft given design category A is considered to be designed to operate in winds of less than Beaufort force 10 and the associated significant wave heights. Typically such conditions might be encountered on extended voyages, for example across oceans, but can also occur inshore when unsheltered from the wind and waves for several hundred nautical miles. Depending on atmospheric conditions, winds can gust to about 32 m/s.

### 3.2 Principal Dimensions

#### 3.2.1 Hull Size

Length of Hull	L <sub>H</sub>	11,480	(m)
Length on waterline	L <sub>WL</sub>	10,200	(m)
Length - max. overall	L <sub>MAX</sub>	11,990	(m)
Beam of hull	B <sub>H</sub>	3,339	(m)
Beam on waterline	B <sub>WL</sub>	3,263	(m)
Beam - maximum	B <sub>MAX</sub>	3,339	(m)
Freeboard fwd	F <sub>F</sub>	1,550	(m)
Freeboard amidships	F <sub>M</sub>	1,365	(m)
Freeboard aft	F <sub>A</sub>	1,274	(m)
Maximum draft	T	1,875	(m)
Air draft: max.	H <sub>A</sub>	16,905	(m)

#### 3.2.2 Maximum Recommended Power

Power measurement to EN ISO 8665 Marine propulsion engines and systems - Power measurements and declarations

Horsepower	50	(hp) (metric)
Kilowatts	37	(kW)



### 3.2.3 Weights

All weights in kilograms (kg)

A 'maximum load' has been used for assessing stability and buoyancy, comprising:

Maximum Recommended Load (ISO 14946) 2500 kg

Essential safety equipment & liferaft 103 kg

Maximum Number of Persons	825
Baggage & other carry on weights	786
Max Load as on Builder's Plate	1611 kg

Maximum capacity of fixed fuel tanks	181
Maximum capacity of fixed water tanks	300
Maximum capacity of fixed holding tanks	150
Weight of fluids in fixed tanks	631 kg

The boat in the 'empty craft condition' has a mass of 8130 kg  
 Unladen weight (lightcraft) including engine 8400 kg  
 Weight Fully Laden 10900 kg

### 3.2.4 Fixed Tanks

Fuel Tanks	Tank Location	Max. Capacity (L)	Filler Location	Drain Location
Diesel tank	Below sole at bottom of companionway	215	Port side deck	N/A

Holding Tanks	Tank Location	Max. Capacity (L)	Deck Pump Out Location	Discharge Valve Location
Black water tank	Below sole, just aft of mast compression post	150	Port side deck, fwd	Below sole just fwd of aft, port cabin door

Other Tanks	Tank Location	Max. Capacity (L)	Filler Location	Drain Location
Fwd FW tank	Below dining seat fwd.	100	Port side deck	-
Aft FW tank	Below dining seat aft	100	Port side deck	0
Inboard FW tank	Below dining seat aft, inboard	100	Port side deck	0

## 4 SYSTEMS DESCRIPTIONS

### 4.1 Bilge Pumps

Bilge Pumps are fitted as follows:

Location	Power	Make & Model	Capacity (Litres/min)	Bilge Compartment(s)
Stbd aft corner of cockpit	Manual	Jabsco 29250	50	Common bilge
Keel sump	Electric	Marco UP1-M	45	Common bilge

The bilge should always be checked after launch. A small amount of water in the bilge is normal. Large amounts of water or any signs of fuel or oil require immediate investigation. Never pump fuel or oil overboard when your boat is in the water.

Check function of pumps regularly & clear debris from their inlets.

It is recommended that a bailer/bucket is carried aboard for emergency bailing purposes. Ensure the bucket is protected against accidental loss.

	<p><b>Warning</b></p>	<p>Never use flammable solvents (i.e. kerosene) for bilge cleaning, however oily it becomes.</p>
---	-----------------------	--

#### Bilge water system

##### 1. Layout option 3 cabins

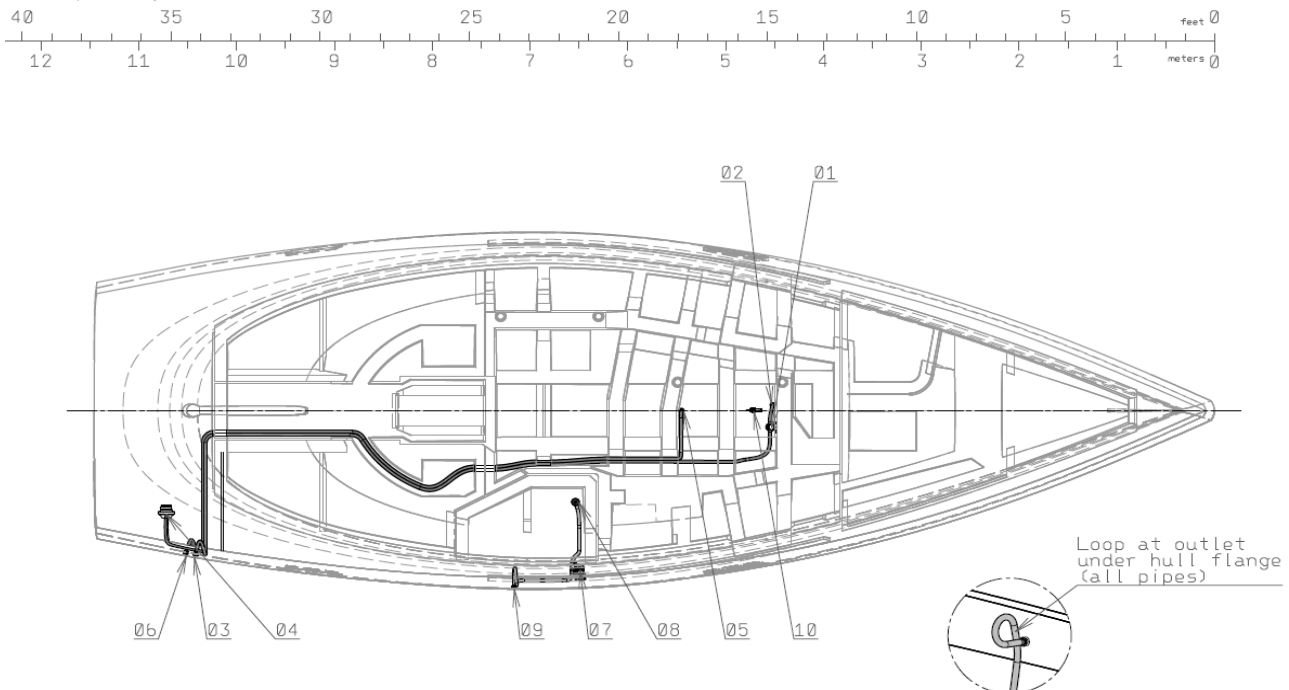

- |                                      |                                      |
|--------------------------------------|--------------------------------------|
| 01 Main electric bilge pump          | 06 Manual bilge pump outlet          |
| 02 Main electric bilge pump strainer | 07 Electric shower pump              |
| 03 Main electric bilge pump outlet   | 08 Electric shower pump strainer     |
| 04 Manual bilge pump                 | 09 Electric shower pump outlet       |
| 05 Manual bilge pump strainer        | 10 Electric shower pump float switch |

## 2. Layout option 2 cabins

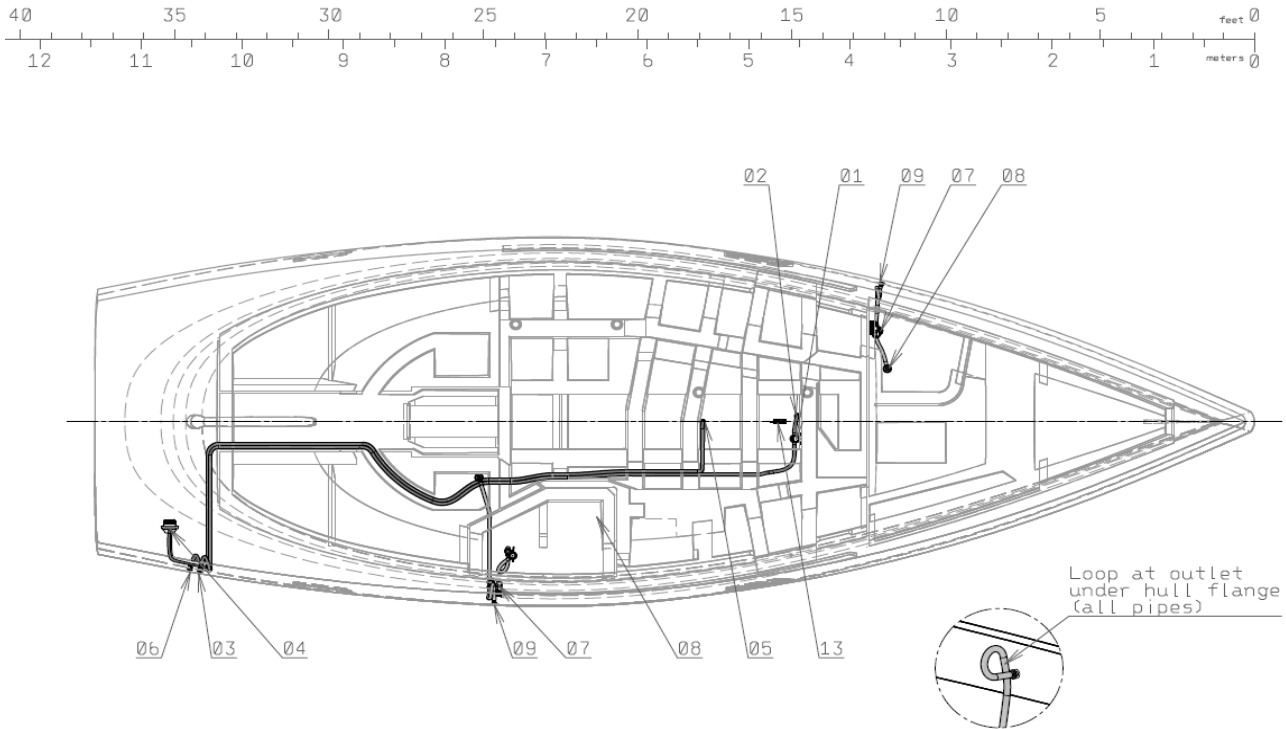

- |                                      |                                      |
|--------------------------------------|--------------------------------------|
| 01 Main electric bilge pump          | 06 Manual bilge pump outlet          |
| 02 Main electric bilge pump strainer | 07 Electric shower pump              |
| 03 Main electric bilge pump outlet   | 08 Electric shower pump strainer     |
| 04 Manual bilge pump                 | 09 Electric shower pump outlet       |
| 05 Manual bilge pump strainer        | 10 Electric shower pump float switch |

## 4.2 Electrical System

ALWAYS.....

- Check battery and charging system condition before going to sea
- Disconnect and remove the battery when the craft is in winter storage (cold weather areas) or long term storage

NEVER.....

- Work on the electrical installation while the system is energised;
- Disconnect shore-power connections when the system is in use.
- Modify the craft's electrical system or relevant drawings: installation, alterations and maintenance should be performed by a competent marine electrical technician;
- Alter or modify the rated current amperage of overcurrent protective devices;
- Install or replace electrical appliances or devices with components exceeding the rated current amperage of the circuit;
- Leave the craft unattended with the electrical system energised, except automatic bilge-pump, fire protection and alarm circuits.

## 4.2.1 DC System

### Description

The direct current (DC) electrical system derives its power from the series of batteries listed below. The batteries supply the components listed in tables below which show the settings of the overload protection breakers/fuses.

The DC system consists of the following circuits:

Battery Bank	Voltage	Rating	Battery Location	Disconnect Switch
Engine & generator start	12	1 x 70Ah	Below aft berths	Aft of battery
Bow thruster	12	2 x 95Ah	Below aft berths	Bove batteries
Consumer	12	2 x 95Ah	Below aft berths	Outboard of batteries

The battery selector switch is located at: N/A: disconnect relay switch only

Main DC Panel Board Location: Above navigation station in port aft corner of saloon

DC fuses are provided in the various circuits as shown in the following table:



### 12 V DC System

Circuit	Rating (A)	Protection
Main supply to consumers	80	Fuse
Anchor winch	80	Fuse
Bilge pump	30	Fuse
Optional consumers	50	Fuse

### Removal of Batteries

To remove the battery cables:

- 1 Turn off all items drawing power from the battery.
- 2 Turn the battery switch to the OFF position
- 3 Remove the negative cable first, then the positive cable. To replace the cables, first replace the positive cable, then the negative.

 Caution	Ensure that the battery space is well ventilated at all times.
 Caution	When charging and (dis)connecting a battery ensure that no water or metal objects can contact the terminals.

## Battery Disconnection

Battery selector switch location: N/A: disconnect relay switch only  
Disconnect switch location(s): See table of batteries on previous page.

Information Batteries should be disconnected when not in use and especially while the boat is unattended.

 Caution	Do not disconnect all batteries while the engine is running; alternator and wiring damage could occur.
---	--

## Battery Maintenance

- 1, Check the fluid levels in the cells (if appropriate for the battery type) approximately every 4 weeks, and weekly in summer and hot zones.
- 2, The fluid level must be between the lower and upper markings.
- 3, Replenish only with distilled water. Do not use metal funnel.
- 4, Coat battery terminal clamps with silicone grease.
- 5, Keep batteries clean and dry.
- 6, The life of some battery types is shortened if drained to zero charge. It is recommended that a battery not be discharged more than 50 percent. If the battery does become run down, recharge it as soon as possible.
- 7, Running the engine to recharge the battery may not be effective. The alternator only creates charging power at higher engine speeds, idling for long periods will not generate enough power to recharge the battery.
- 8, If you need to charge a battery, use only a battery charger designed to charge automotive/marine batteries. Use charger only when batteries are disconnected from the boat's electrical circuit. Follow the charger instructions.
- 9, If your boat will not be used for several weeks remove the batteries from the boat and connect them to a charger.

## 4.2.2 AC System

The alternating current (AC) system is supplied with power by the sources listed below. These supply the components listed in tables below which show the settings of the overload protection breakers/fuses.

The system is: 230 V  
unpolarised

The AC system consists of the following sources of power:





Source of power	Number	Location
Shore connection	2	Transom - below helm seat
Generator	1	Optional - aft of engine
Inverter	1	Optional - below stbd aft berth

The power source selector switch is located on the AC panel board.

The main switch board location: Above navigation station in port aft corner of saloon

	<p>Caution</p>	<p>The RCD (residual current device) should be tested monthly by pressing the "TEST" button. The RCD should trip "OFF" immediately. Reset the RCD by flicking the switch back to "ON". If the RCD does not trip "OFF" immediately, there is a fault: disconnect all AC power sources and call a qualified electrician to investigate.</p>
--	----------------	---

Information To avoid a power spike, turn OFF all main breakers before plugging IN the shore power cord. Securely connect the power inlet of the boat and the shore power receptacle. If the connection is broken and later re-secured, the main breaker will trip. Connections must be secure for uninterrupted dock-side service.

	<p>Caution</p>	<p>Connect metallic housings or enclosures of installed electrical appliances to the protective conductor system in the craft (green or green with yellow stripe conductor).</p>
	<p>Caution</p>	<p>Use double insulated or grounded (earthed) electrical appliances.</p>
	<p>Danger</p>	<p>Do not allow the shore-power cable end to hang in the water. An electrical field can be caused which can cause injury or death to nearby swimmers.</p>
	<p>Warning</p>	<p>To minimise shock and fire hazards:</p> <ul style="list-style-type: none"> <li>• Turn off craft's shore-power connection switch before connecting or disconnecting shore-power cable.</li> <li>• Connect shore-power cable to craft's inlet before connecting to shore power source.</li> <li>• Disconnect shore-power cable at shore-power source first.</li> <li>• Close shore-power inlet cover tightly.</li> <li>• Do not alter shore-power cable connectors &amp; use only compatible connectors.</li> </ul>

## 4.2.3 Control panel

### FRONT SIDE

The SIMARINE Power Panel is divided into 6 sections.

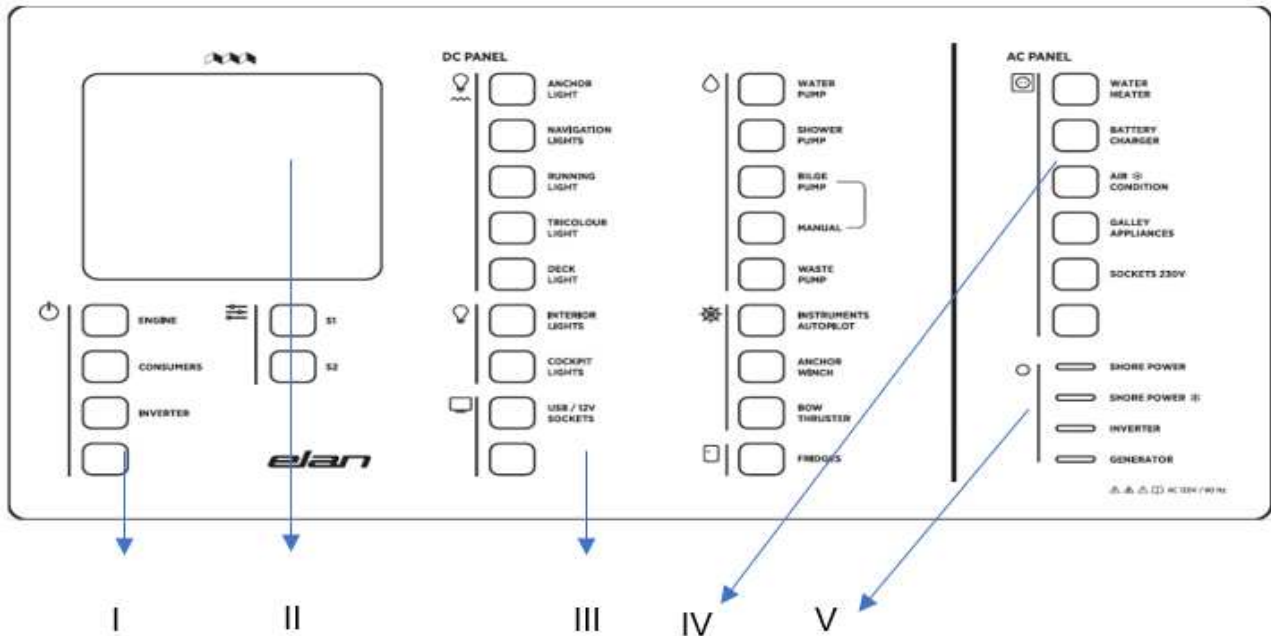

- I. REMOTE / MAIN SWITCHES
- II. DISPLAY / BATTERY MONITOR UNIT – SIMARINE PICO
- III. DC SWITCHES
- IV. AC SWITCHES
- V. INDICATOR LIGHTS

#### I. REMOTE / MAIN SWITCHES

This section controls the external remote/main switches.

##### TO TURN ON

1. Press and hold the desired switch for one second.
2. The indicator around the switch will light up blue.

##### TO TURN OFF

1. Press and hold the desired switch for one second.
2. The indicator around the switch will turn off.

The RED light indicates there is no backward communication from the remote/main switch.

## II.DISPLAY / BATTERY MONITOR UNIT – SIMARINE PICO

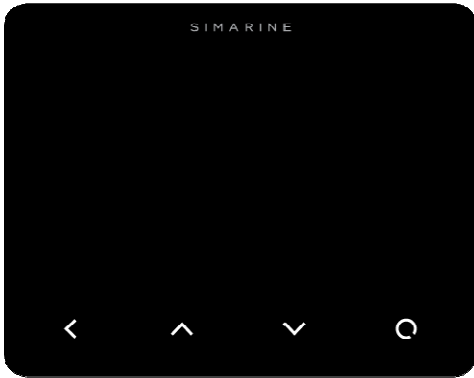

### •BACK

Press “BACK” to move on to the previous instance in hierarchical order.

In SETTINGS mode:

Press “BACK” to move on to the previous menu instance in hierarchical order.

### •UP

Press “UP” to display the next screen.

In SETTINGS mode:

Press “UP” to move the selection onto the item above.

### •DOWN

Press “DOWN” to display the previous screen.

In SETTINGS mode:

Press “DOWN” to move the selection onto the item below.

### •ENTER - Confirm/Settings

Press and hold “ENTER” to enter the SETTINGS.

In SETTINGS mode:

Press to display additional settings for the highlighted item (for items with an arrow on the right).

Press “ENTER” to confirm/set the highlighted item (for items without an arrow on the right).

## III.MEMORY / SCENE SWITCHES

### TO RECALL A DESIRED SCENE

- 1.Press and hold the desired switch for two seconds to call up the desired DC/AC scene setting.
- 2.The indicators around the DC and AC switches selected by the scene setting will light up blue.

### TO STORE A DESIRED SCENE

- 1.Press and hold the desired switch you want to store the current DC/AC scene setting to for five seconds.
- 2.A prompt will appear on the display asking if you want to store the current settings on the desired MEMORY / SCENE switch.
- 3.Hold ENTER on the display unit for 1 second to store or press BACK to cancel.



## IV.DC SWITCHES

### TO TURN ON

- 1.Press the desired DC switch.
- 2.The indicator around the switch will light up blue.

### TO TURN OFF

- 1.Press the desired DC switch again.
- 2.The indicator around the switch will turn off.

The RED light indicates that the circuit breaker was broken and needs to be replaced or there is no power provided to the switch.

The GREEN light indicates that the OVERRIDE switch on the back of the panel is set to ALWAYS ON mode. This setting cannot be changed using the buttons on the front panel or the iPad app.

## V.AC SWITCHES

### TO TURN ON

- 1.Press the desired switch.
- 2.The indicator around the switch will light up blue.

### TO TURN OFF

- 3.Press the desired AC switch again.
- 4.The indicator around the switch will turn off.

## VI.INDICATOR LIGHTS

The indicator lights will light up blue when a specific consumer/generator is turned on or shore power connection is present.

## BACK SIDE

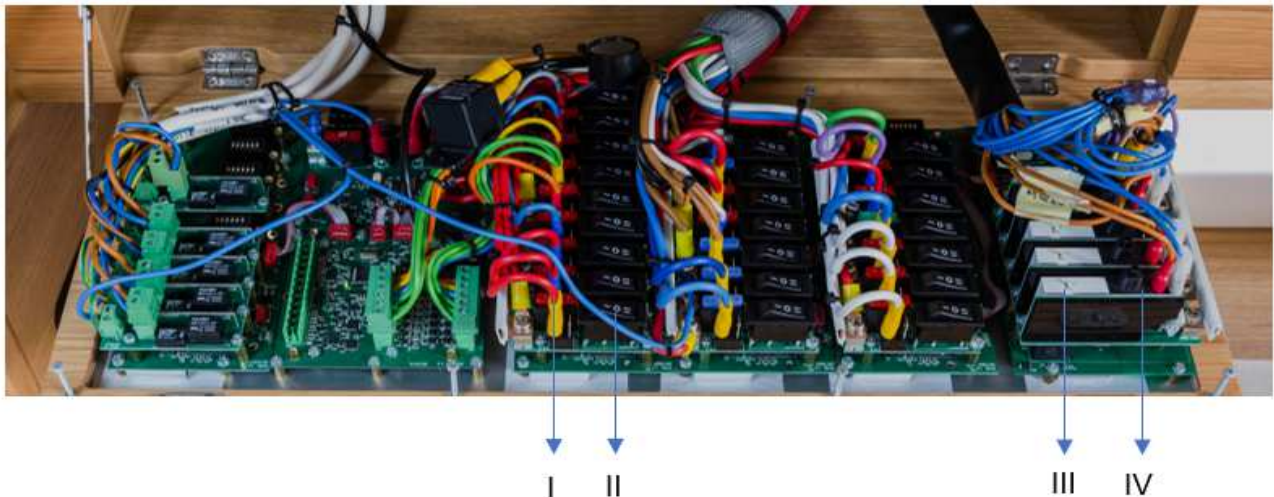

I.FUSE

II.OVERRIDE SWITCHES - DC

III.OVERRIDE SWITCHES - AC

IV.AC CIRCUIT BREAKER RESET BUTTON

### I.CIRCUIT BREAKER

SIMARINE NEREIDE conveniently utilizes standard automotive fuse.

If a circuit breaker is broken, the RED light will lid the button on the front panel and indicate that the fuse needs to be replaced.

### II.OVERRIDE SWITCHES – DC

The override switches provide a convenient safety analog switching feature that overrides the digital setting on the front panel or the iPad application.

ALWAYS ON

Push the desired over ride switch to position “I”.

ALWAYS OFF

Push the desired over ride switch to position “0”.

DIGITAL SETTING (via front panel or iPad App)

Push the desired over ride switch to position “II”.

### III.OVERRIDE SWITCHES – AC

TURN ON

Push the desired over ride lever to the RIGHT position.

TURN OFF

Push the desired over ride lever to the LEFT position.

#### IV.AC CIRCUIT BREAKER RESET BUTTON

##### RESET CIRCUIT BREAKER

Push the button to reset the circuit breaker.

#### V.AC CIRCUIT BREAKER RESET BUTTON

WATER 300l		WATER op. 270l		FUEL 215 l		WASTE 100l	
50l	24 ohm	0 l	0 ohm	0 l	10 ohm	0 l	240 ohm
100l	67 ohm	50l	14 ohm	20l	53 ohm	30 l	197 ohm
150l	87 ohm	100l	72 ohm	40 l	77 ohm	50 l	125 ohm
200l	132 ohm	150 l	120 ohm	215 l	180 ohm	70 l	76 ohm
250l	171 ohm	200 l	176 ohm			90 l	40 ohm
300l	190 Ohm	270 l	190 ohm			100 l	30 ohm

## MAIN PANEL FUSES

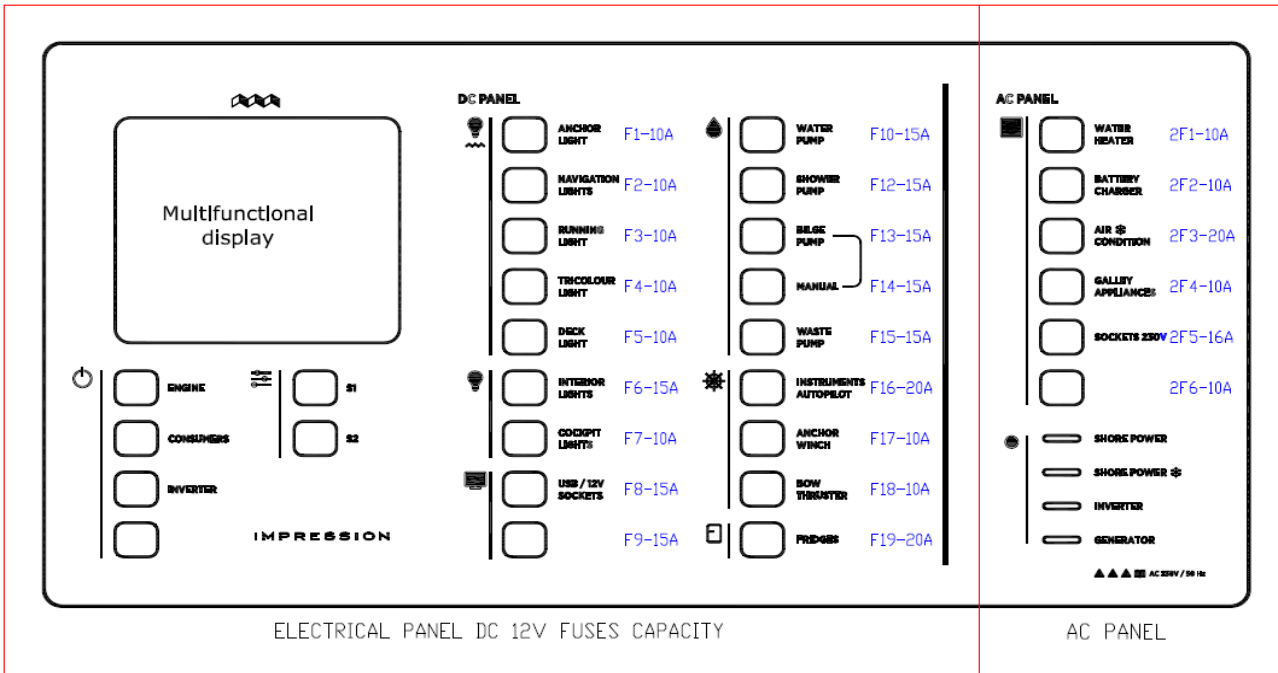

## DISTRIBUTION STRIPS

DISTRIBUTION STRIP 1

DISTRIBUTION STRIP 2

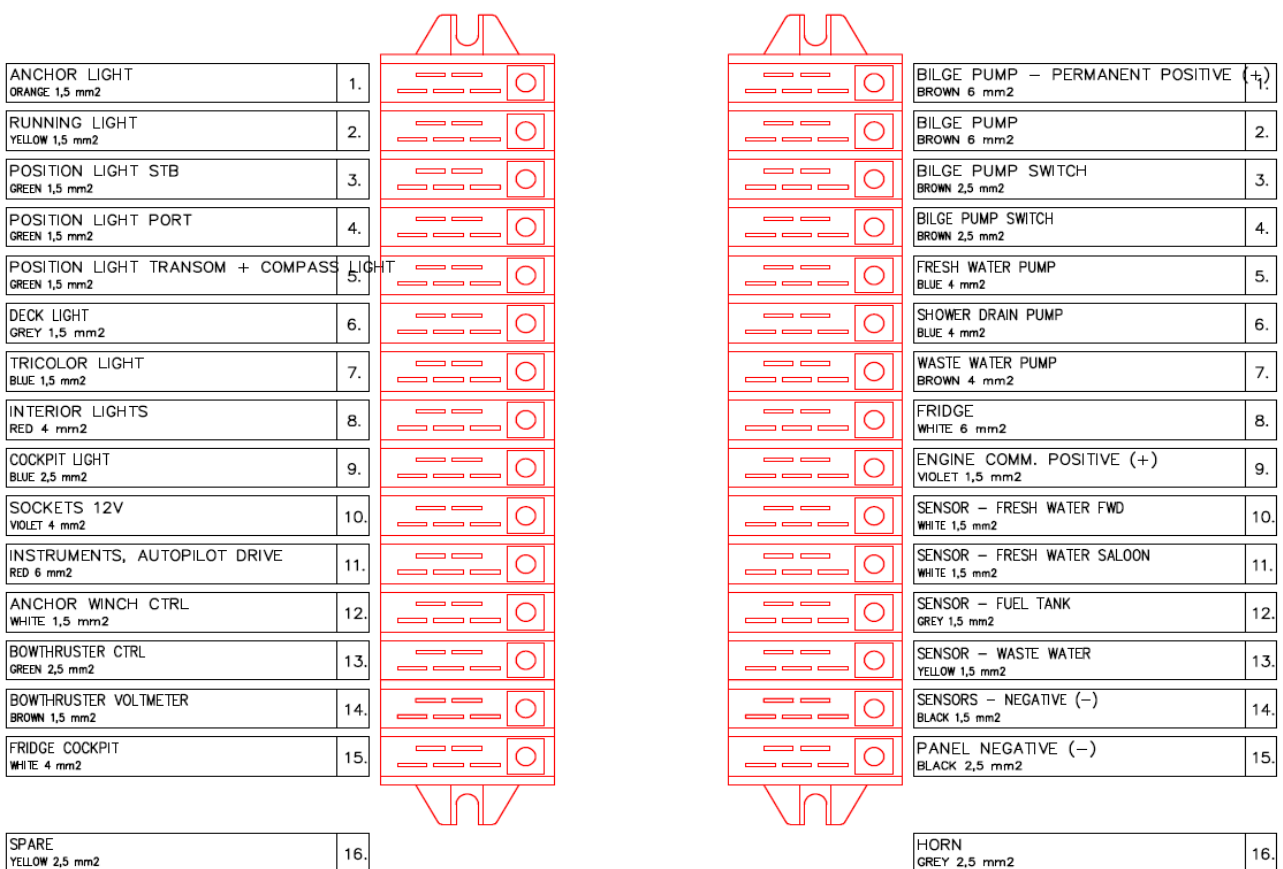

### 4.3 Fuel System







The craft has: Permanently installed Diesel fuel system

The following components are supplied by the fuel system:

Item	Number	Location
Engine	1	Below companionway steps
Air heater (optional)	1	Aft of engine

Refer to manufacturer's instructions for details of the above equipment.

For details on tanks, refer to section: 3.2.4

 Warning	Do not smoke or use open flame when filling with fuel, when working on the fuel system and when in the engine room.
 Danger	Never use a flame to check for leaks
 Warning	Inspect fuel lines at least annually. Replace if deterioration or openings are found.
 Caution	All components that burn fuel require an air supply. Ensure all air intakes are clear before fuel burning components are running.
 Warning	If leakage is detected, close the fuel shut-off valve, and have the system repaired before further use. System repairs should be made by a competent person.
 Danger	Bio-fuels and fuels that have significant alcohol content, can attack plastic fuel tanks. Such fuels should not be used in this craft.

## FUEL SYSTEM

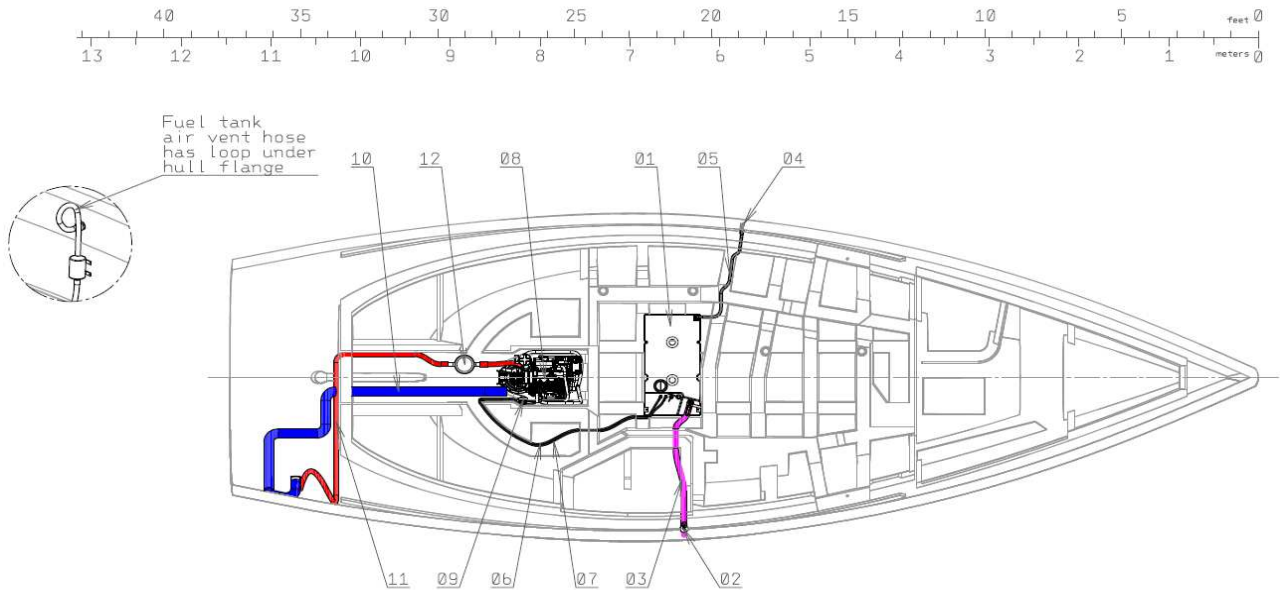

- |                                |                               |
|--------------------------------|-------------------------------|
| 01 Fuel tank                   | 07 Fuel return line           |
| 02 Fuel tank inlet deck filler | 08 Diesel engine Volvo/Yanmar |
| 03 Fuel tank inlet hose        | 09 Fuel filter                |
| 04 Fuel tank air vent          | 10 Engine room ventilation    |
| 05 Fuel tank air vent hose     | 11 Exhaust hose               |
| 06 Fuel supply line            | 12 Waterlock                  |











## 4.4 Gas System

### Description of System

The gas (LPG) system supplies the consumers listed below from the gas bottles located in the locker. The locations of the key components and controls are also listed below.

Gas Consumers Fitted Onboard	Location
Stove	Galley - stbd side
BBQ (optional)	Under helm stbd seat

Key Controls & Fittings	Location
Gas locker	In box in transom cut-out
Regulator	On bottle valve
Manual shut-off valve	In locker immediately below stove

 Caution	Read the supplied appliance manufacturers instructions before using any part of the gas system.
 Caution	Close fuel supply-line valves and cylinder valves when appliances are not in use. Close valves before refuelling and immediately in an emergency. Be sure that appliance valves are closed before opening the cylinder
 Caution	Do not use cleaning solutions containing ammonia
 Warning	Do not obstruct access to LPG system components in any way
 Caution	Keep valves on empty cylinders closed and disconnected. Keep protective covers, caps or plugs in place. Store reserve cylinders in ventilated housings on open decks or in gas-tight lockers which are vented overboard and intended for that purpose.
 Caution	Do not use LPG cylinder housing or cylinder lockers for storage of any other equipment.
 Caution	Never leave craft unattended when LPG consuming appliances are in use.
 Danger	Do not smoke or use open flame when replacing LPG cylinders.
 Danger	Fuel-burning open-flame appliances consume cabin oxygen and release products of combustion into the craft. Ventilation is required when appliances are in use.
 Danger	Open designated vent openings while appliances are in use. Do not use the stove or oven for space heating. Never obstruct ventilation openings.

## GAS SYSTEM SCHEME

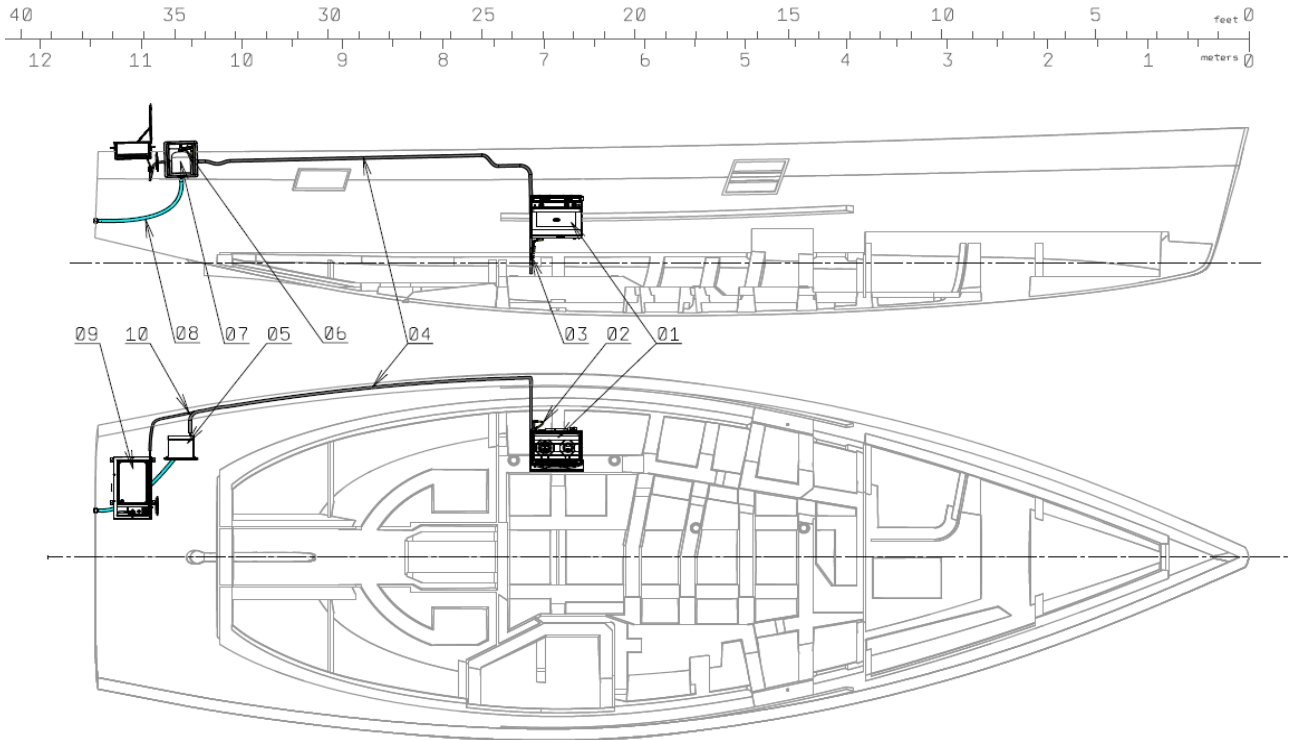



- |                           |                             |
|---------------------------|-----------------------------|
| 01 Gas cooker             | 06 Safety screw valve       |
| 02 Flexible hose          | 07 Gas bottle               |
| 03 Gas valve              | 08 Gas compartment drainage |
| 04 Copper tube            | 09 Gas grill (Optional)     |
| 05 Gas bottle compartment | 10 T-Joint (Optional)       |

The following vents should be opened when using the gas system:

Vent Description & Location
Grill in washboard
Engine space vents
Saloon vent hatch
Vents both sides of companionway



### 4.4.1 Procedure for Changing Gas Cylinder



 <p>Caution</p>	<p>Never allow gas cylinders to fall. Keep caps in position on the bottle neck while moving cylinders. Use a gas cylinder cart while transporting long distances. Keep stored gas cylinders secure at all times.</p>
 <p>Caution</p>	<p>Never turn the regulator valve directly from 'on' to the 'disconnect' position. Always wait until the flame is completely out. If gas escapes when regulator is removed, replace it immediately to stop leak, then call a local gas supplier. Never disconnect regulator if flame stays lit.</p>

- 1 Turn the regulator switch to 'off'.
- 2 Press the 'disconnect' button at base of regulator to release regulator from the valve of the empty cylinder and lift regulator off valve.
- 3 Refit the safety cap onto the empty cylinder valve immediately.
- 4 Remove the new cylinder's valve safety cap.
- 5 Ensure the regulator's gas switch is set to 'off' position.
- 6 Place regulator over cylinder valve and press down firmly onto valve until you hear a definite 'click'.
- 7 Make an inspection of the connections and if satisfied that all is securely fastened, turn the regulator switch to 'on'.
- 8 Check pressure gauge indicates a satisfactory reading.

### 4.4.2 Inspection of Gas System

Test the LPG system for leakage regularly. Check all connections for leakage by:

- 1 routine observation of the bubble-leak detector (if fitted)
- 2 observation of the pressure gauge for pressure drop with appliance valves closed and cylinder valve opened, then closed (if fitted with gauge on supply pressure side)
- 3 manual leak testing
- 4 testing with soapy water or detergent solution (with appliance-burner valves closed and cylinder and system valves open)

 <p>Caution</p>	<p>LPG lines must be inspected regularly, at least annually, and replaced if any deterioration is found.</p>
 <p>Danger</p>	<p>Never use a flame to check for leaks.</p>
 <p>Caution</p>	<p>If leakage is present, close the cylinder valve and have the system repaired before further use. System repairs should be made by a competent person.</p>



## 4.5 Steering System

Information The boat's steering system has the following components:

Steering Hardware: Wheel  
 Turning device: Rudder  
 Mechanism: Wire rope and pulley

The craft is fitted with the following steering position(s):

- 1 Port side of aft cockpit
- 2 Stbd side of aft cockpit

	Caution	Refer to the system manufacturer's documentation for information pertaining to the steering gear.
	Caution	All components of the steering system must undergo periodic inspection & maintenance to ensure safe operating conditions. Refer to the maintenance section of this manual for further details.
	Warning	Failure of the steering system will cause loss of control of your boat. Any change in steering such as looseness, tightness, binding, etc., must be checked immediately by a qualified person.

### 4.5.1 Emergency Steering arrangements

Information Should the steering system fail, the craft may be steered at low speed by an emergency means of steering, as described below:

An emergency tiller can be fitted directly to the crown of the rudder stock.

The emergency tiller is located Cockpit locker

Instructions for fitting the emergency tiller:

Remove cap on centreline of cockpit sole and pass through the tiller so that its socket fits onto the crown of the rudder stock. Steer directly from the aft end of the cockpit





	Caution	Be aware that vision from the emergency steering position may be restricted. Ensure that a lookout is posted at all times.
---	---------	--

## 4.6 Black Water System

In many parts of the world the discharge of black and even grey water is restricted. This vessel has fittings, described below, to meet these restrictions

Information Refer to the following section for details on tanks: 3.2.4

Head	Discharge	Location of Valves
Fwd head	Discharges directly to holding tank	No Y-valve: tank discharge only
Aft head	Discharges directly to holding tank	No Y-valve: tank discharge only

 <p>Caution</p>	<p>If navigating waters where discharge is restricted, the last discharge valves may need to be sealed by an authority.</p> <p>Vent is of adequate size &amp; arrangement</p>
 <p>Caution</p>	<p>Never allow holding tanks to be over-filled as this will risk back-flooding to the craft interior.</p>
 <p>Caution</p>	<p>Do not allow holding tanks to freeze in cold weather as expansion may risk rupture of fittings. Apply some anti-freeze to the tank in times of cold weather.</p>
 <p>Caution</p>	<p>Empty holding tanks when the craft is to be left unattended</p>

### BLACK WATER SYSTEM

#### 1. Layout option 3 cabins

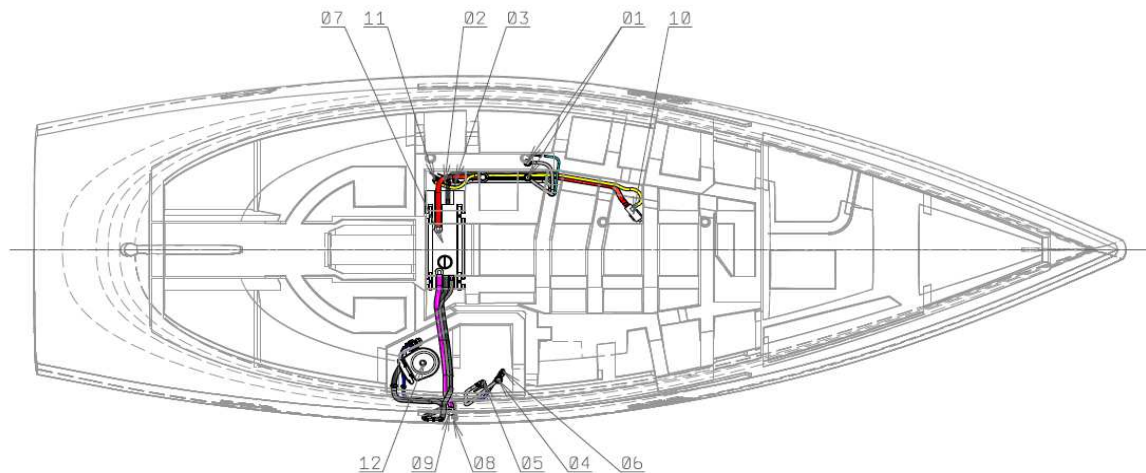

- |                                   |                                  |
|-----------------------------------|----------------------------------|
| 01 Galley sink outlet             | 07 Black water holding tank      |
| 02 Galley sink gray water seacock | 08 Holding tank airvent          |
| 03 Toilet sink outlet             | 09 Dockside deck discharge gland |
| 04 Toilet sink gray water seacock | 10 Macerator pump                |
| 05 Toilet flush water seacock     | 11 Macerator pump outlet seacock |
| 06 Black water holding tank       | 12 Manual toilet                 |

## 2. Layout option 2 cabins

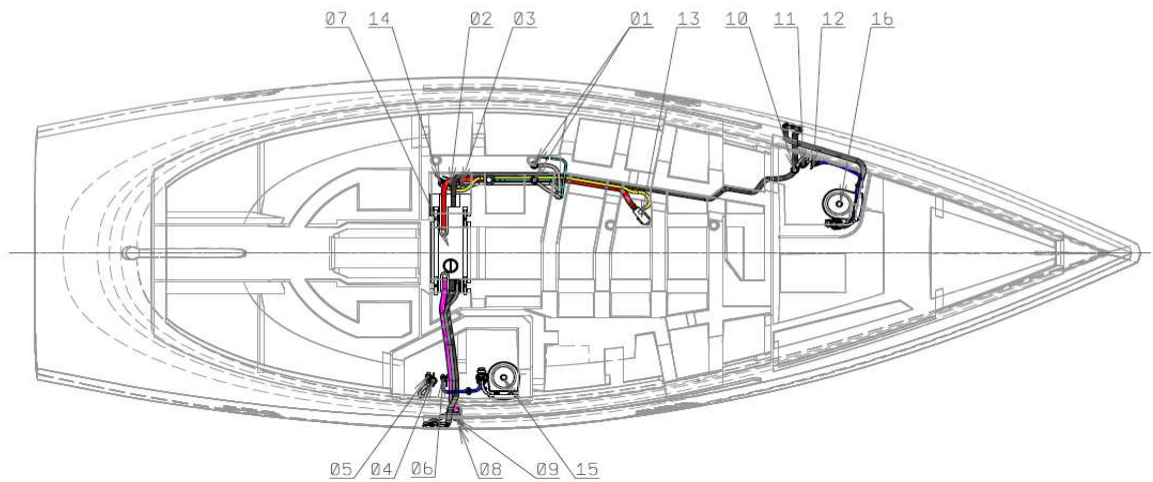
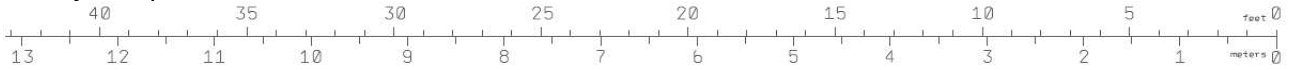

- |                                   |                                       |
|-----------------------------------|---------------------------------------|
| 01 Galley sink outlet             | 09 Dockside deck discharge gland      |
| 02 Galley sink gray water seacock | 10 FWD toilet sink outlet             |
| 03 Sea water inlet seacock        | 11 FWD toilet sink gray water seacock |
| 04 Toilet sink outlet             | 12 FWD toilet flush water seacock     |
| 05 Toilet sink gray water seacock | 13 Macerator pump                     |
| 06 Toilet flush water seacock     | 14 Macerator pump outlet seacock      |
| 07 Black water holding tank       | 15 Manual toilet                      |
| 08 Holding tank airvent           | 16 FWD manual toilet                  |

## 4.7 Thrusters

The craft is fitted with thrusters as follows:

Thruster	Power Source
Bow	Electric
Stern	Not fitted

These units are controlled by joystick from the steering position.

	<p><b>Caution</b></p> <p>Ensure the joysticks are in neutral to prevent the thrusters from running when not required.</p>
---	---

## 4.8 Anchor Windlass

**Information** The craft is fitted with a powered anchor windlass on the foredeck. The windlass can be operated by local controls at the unit or by remote control from either steering position.

	<p><b>Warning</b></p> <p>Winches and windlasses generate large forces by the push of a button. Always:</p> <ul style="list-style-type: none"> <li>• keep hands and feet away from the windlass</li> <li>• have experienced crew operate the windlass</li> <li>• prevent accidental pressing of switches</li> </ul>
---	--

## 4.9 Fresh Water System

Information The hot and cold fresh water system onboard the craft supplies the following items:

Item	Location
Deck shower	Aft deck
Galley sink	Galley

Information The fresh water system is pressured by the following pumps:

Description	Pump Location	Voltage	Control
Electric pump	Engines space	12VDC	Dashboard

Information Hot water is provided by the following means:

### FRESH WATER SYSTEM

#### 1. Layout option 3 cabins

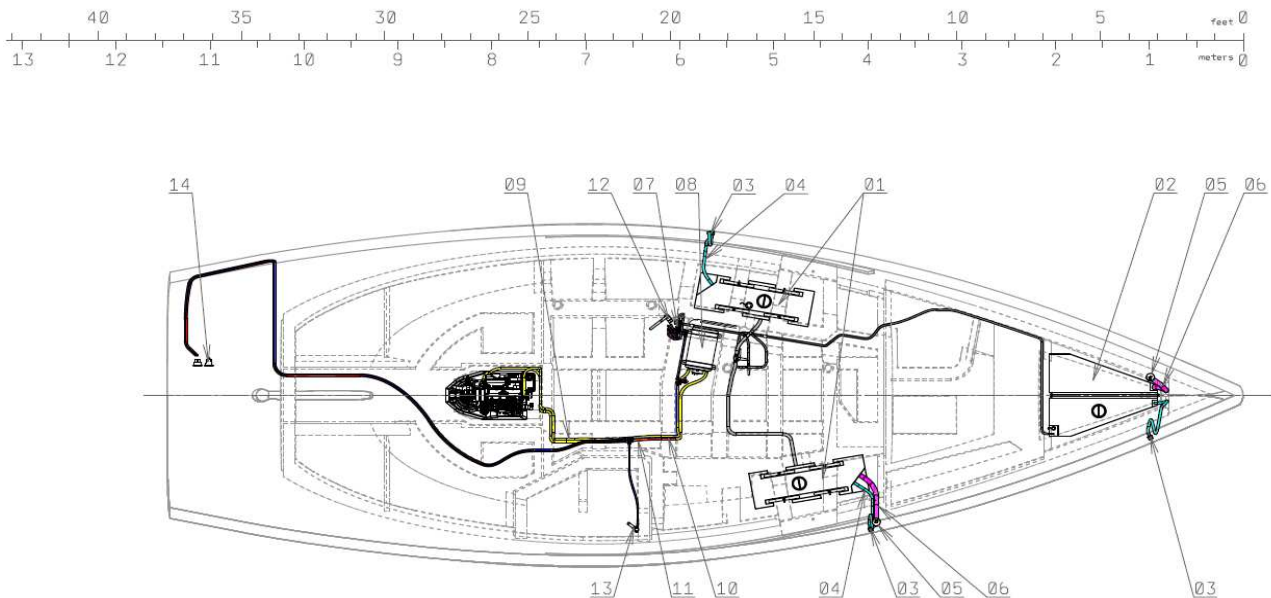

- |                                |                              |
|--------------------------------|------------------------------|
| 01 Fresh water tank (Std.)     | 08 Water heater              |
| 02 Fresh water tank (Optional) | 09 Engine coolant circ. Hose |
| 03 Air vent                    | 10 Cold water tube           |
| 04 Tank ventilation hose       | 11 Hot water tube            |
| 05 Fresh water deck filler     | 12 Galley mixer tap          |
| 06 Fresh water filler hose     | 13 Toilet mixer tap          |
| 07 Electric fres water pump    | 14 Cockpit shower mixer tap  |

2. Layout option 2 cabins

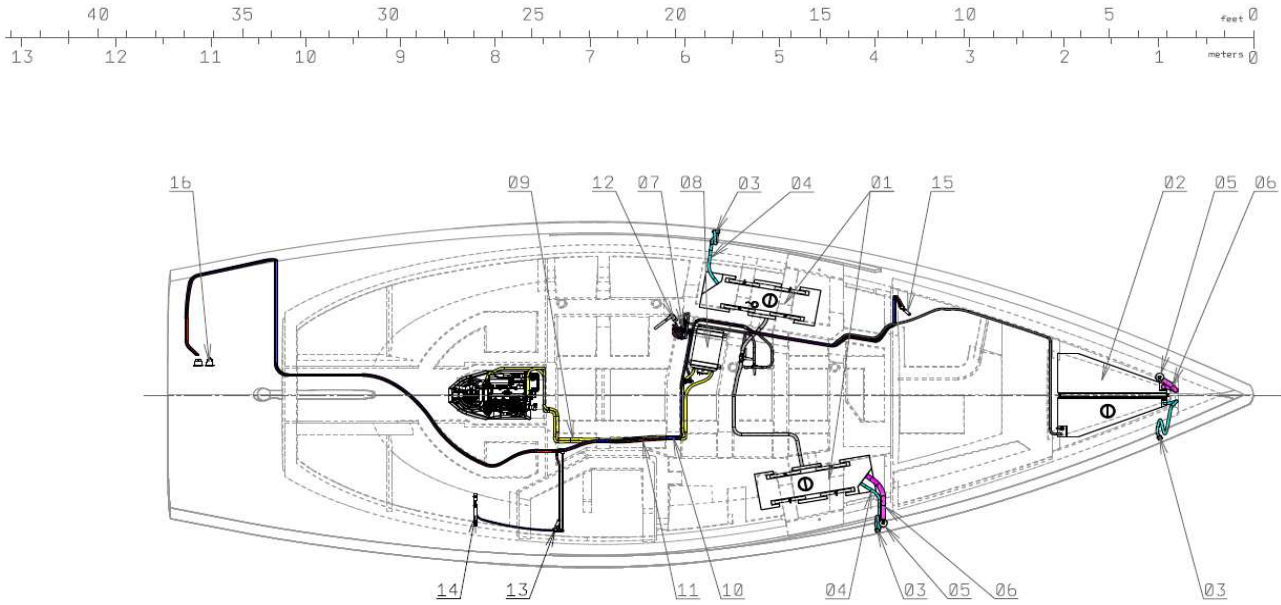

- |                                |                              |
|--------------------------------|------------------------------|
| 01 Fresh water tank (Std.)     | 09 Engine coolant circ. Hose |
| 02 Fresh water tank (Optional) | 10 Cold water tube           |
| 03 Air vent                    | 11 Hot water tube            |
| 04 Tank ventilation hose       | 12 Galley mixer tap          |
| 05 Fresh water deck filler     | 13 Toilet mixer tap          |
| 06 Fresh water filler hose     | 14 Toilet shower mixer tap   |
| 07 Electric fresh water pump   | 15 Front toilet mixer tap    |
| 08 Water heater                | 16 Cockpit shower mixer tap  |

## 5 PRE-LAUNCH OBSERVATIONS



### 5.1 Recommended Safety Equipment

	Caution	The sea can be unpredictable. Be prepared by carrying the following equipment, as a minimum, at all times.
---	---------	--

- 1 Life jacket or buoyancy aid for each person
- 2 Appropriate weatherproof clothing
- 3 Compass
- 4 Charts
- 5 Anchor and line
- 6 At least 2 warps - see section 6.5
- 7 First aid kit including compress and thermal blanket
- 8 Bucket
- 9 Distress flares
- 10 VHF radio
- 11 Binoculars
- 12 Knife in protective sheath
- 13 Drinking water

### 5.2 Risk of Loss of Stability

The stability and buoyancy of this boat has been assessed on the basis of the weights specified in section: 3.2.3



	Warning	The boat should never carry more than the manufacturer's recommended load. The load should be suitably distributed, bearing in mind that stability is most significantly reduced by any weight added high up in the boat
	Caution	Stability can also be adversely affected by sloshing fluid. Bilge water should be kept to a minimum

If excessive sail is carried, THIS BOAT MAY CAPSIZE, but is designed not to sink if this occurs. knots. Particular care should be taken in gusty wind conditions.

This boat has been assessed using the Stability Index (STIX), which is a measure of the overall stability safety and considers the effects of boat length, displacement, hull proportions, stability characteristics and resistance to downflooding. This assessment has yielded the following data:

	Min operating condition	loaded arrival condition
STIX:	44	40
Angle of vanishing stability:	127	123





	Warning	Loose equipment can cause damage to the craft and affect stability. Ensure all loose equipment is properly stowed before setting out.
	Caution	Stability may be reduced when towing or lifting heavy weights using a davit or boom.
	Caution	Breaking waves are a serious stability hazard

### 5.3 Risk of Flooding

	Caution	The following openings are marked "WATERTIGHT OPENING - KEEP SHUT WHEN UNDER WAY" and care should be taken to observe this warning:
---	---------	---

1. Cockpit lockers x 2

	Caution	In rough weather, hatches, lockers and companionway/doorways should be closed to minimise the risk of water ingress.
	Caution	Care should be taken to ensure that the cockpit drains are not blocked and that the cockpit can drain freely.
	Caution	Ensure all limber holes are clear

#### 5.3.1 Through Hull Fittings including Seacocks

The following skin fittings are fitted in the hull of the craft. They provide the frontline defence against flooding and should be regularly inspected for condition. Valves should be frequently operated to ensure free movement.

In addition, it is recommended that all but drains & bilge discharges are closed when the craft is to be left unattended.

Ref.	Description	Location	Means of Closure
1	Holding tank discharge	Below sole just fwd of aft, port cabin door	Manual valve to tank & then heads
2	Fwd head water intake	Below sole just outside fwd head door	Manual valve on skin fitting and diaphragm pump on head
3	Aft head water intake	`	Manual valve on skin fitting and diaphragm pump on head
4	Fwd head sink discharge	Below sole just outside fwd head	Manual valve
5	Aft head sink discharge	Below sole, just inboard of the aft	Manual valve
6	Galley sink drains (2 sinks to	Below galley sole	Manual valve
7	Log	Below sole in fwd central corridor	Screwed fitting and cap if
8	Depth transducer	Below sole in fwd central corridor	Screwed fitting and cap if
9	Seawater inlet (optional)	Below galle sole	Manual valve with supply to



### 5.3.2 Strainers

Information Bilge pump intakes inside the boat, and intakes of water from outside the boat are fitted with protective baskets to avoid blockage by weed, leaves or other debris. Ensure these are kept clear at all times.

## 5.4 Risk of Fire

Information Always keep the bilges clean and check for fuel & gas regularly

Information	<p><b>NEVER</b></p> <ul style="list-style-type: none"> <li>• obstruct portable extinguishers in lockers</li> <li>• obstruct safety controls (shut off valves, switches)</li> <li>• leave the craft unattended whilst cooking/heating appliances are in use</li> <li>• stow combustible material in engine space. If other items are</li> <li>• modify craft's systems, especially fuel &amp; gas.</li> <li>• fill any fuel tank whilst machinery is running</li> <li>• replace gas bottles whilst gas is in use</li> <li>• smoke while handling fuel or gas</li> <li>• fit curtains above cookers</li> <li>• use gas lights in craft</li> </ul>
-------------	---

### 5.4.1 Fire Fighting Equipment

 <p>Caution</p>	<p>Location and capacity of extinguishers is given below. It is the responsibility of the boat owner/operator to:</p> <ul style="list-style-type: none"> <li>• check equipment at intervals as stated on equipment,</li> <li>• replace any extinguisher, if used, with one of same rating</li> <li>• inform members of the crew about location and operation of all fire fighting devices</li> </ul>
--	--

#### Portable Extinguishers

Location & Description	Medium	Rating/ Capacity
Cockpit locker	Powder	1kg
Below bottom companionway step	Powder	2kg
Galley	Powder	1kg
Galley	Fire Blanket	N/A

## 5.4.2 Fire Escapes



The following escapes are provided onboard the boat:

Opening Type	Location
Companionway	Aft end of saloon, on centreline
Hatch	Fwd cabin deckhead

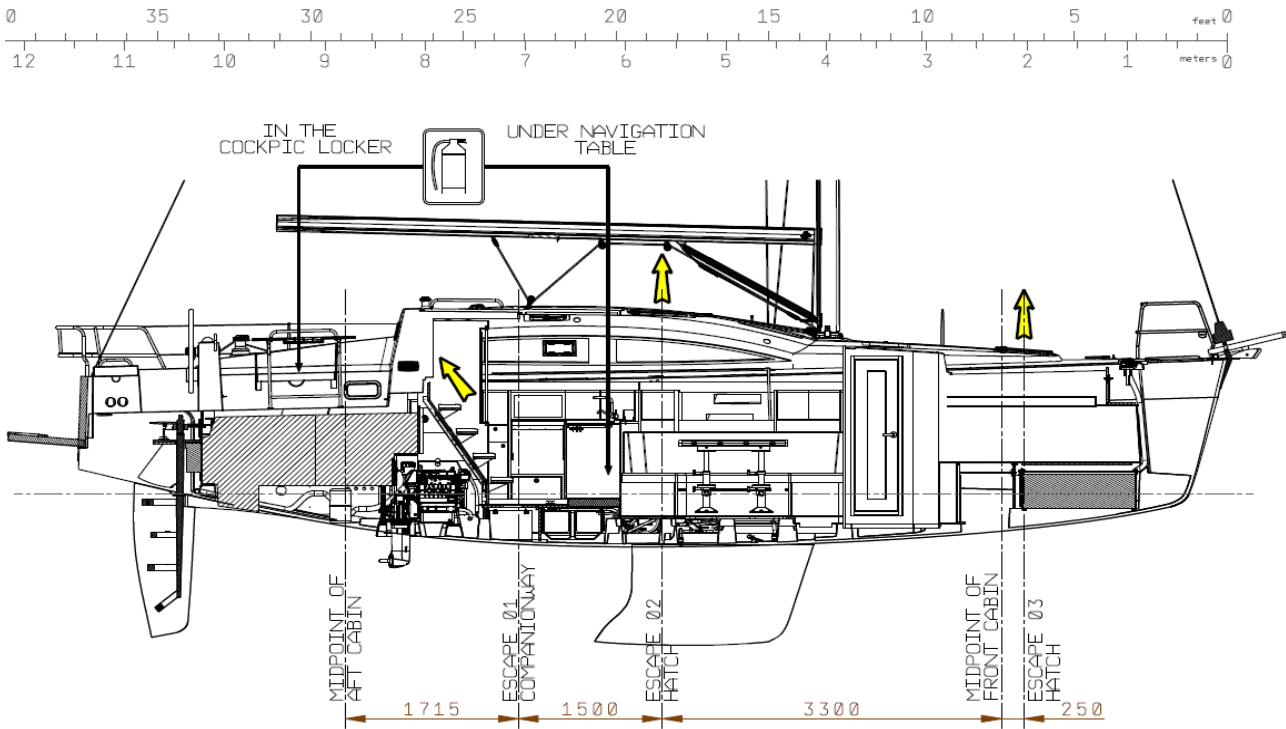
### FIRE ESCAPE PLAN & PROTECTION



Information Exits other than the main companion way & hatches with ladders are labelled

	Caution	It is the responsibility of the boat owner/operator to inform crew of the location of routes and exits.
	Warning	NEVER obstruct exits

## 5.5 Risk of Falling Overboard

**Information** The working deck is the area of the boat that is safe for use at all times. Areas outside the specified working deck should only be used whilst leaving or arriving at a mooring or whilst the boat is not underway.

On this boat, the working deck area is defined as:

All deck areas inside the guard wires, excluding the coachroof

For maximum weight limit see: 3.2.3

For crew area limits, see section: 5.2

 <p>Caution</p>	<p>The guardwires have a limited life-span. They should be inspected annually for any signs of fraying and replaced if any damage is found.</p>
--	---

**Information** In the event of a member of the crew falling overboard they should be recovered using:

TRUE

 <p>Caution</p>	<p>Care should be made to ensure the person being recovered is not pushed under the platform if the vessel is pitching. Consider recovery by use of a dinghy if necessary.</p>
--	--

 <p>Warning</p>	<p>Most slips and falls occur during boarding and disembarking. Be aware that wet decks can be slippery. Wear slip resistant footwear at all times.</p>
---	---

## 5.6 Liferaft stowage

 <p>Warning</p>	<p>A liferaft with sufficient capacity to accommodate the maximum number of crew should be carried onboard.</p>
--	---

**Information** A liferaft may be stowed: On coachroof/deck  
 Maximum weight of 64 kg  
 liferaft:

 <p>Warning</p>	<p>Do not carry the liferaft in a higher location than the position noted above.</p>
--	--

## 6 NAVIGATION & OPERATION

### 6.1 Use of Engines

The craft is fitted with the following motive power:

- Engine Compression ignition
- Volvo & Yanmar options (Engine installed Volvo D240)
- Propeller 3 blade folding (from Volvo)



Information

Before starting the engine:

- Check engine compartment for fumes.
- Check fuel lines for damage & leaks.
- Check the bilge water level.
- Ensure that ventilation openings are clear to prevent overheating
- Run engine compartment blower for 4 minutes before starting the engine
- Ensure there is sufficient fuel for the anticipated journey - including a margin for contingencies.

Take care not to damage fuel lines and check regularly that they are in good condition



Avoid placing flammable materials on or near hot parts.

 <p>Danger</p>	<p>If a fuel leak or fumes are detected, do not start the engine. Ensure all crew leave the boat and have a qualified person repair the fault as soon as possible.</p>
 <p>Caution</p>	<p>So as to avoid moving parts, never access the engine space when engines are running.</p>

## 6.2 Handling Characteristics

Information This craft is primarily intended to be supported by a combination of buoyancy and planing forces

Information Maximum engine power: 37 kW 50 hp  
 Information Periodic inspection of the propeller for excessive wear or damage is recommended in order to maintain peak performance and to maximise the longevity of the engine.

 Caution	Seaways are infinitely variable and all craft can meet conditions that will challenge the boats handling characteristics and/or the helmsman's ability. Proceed with a margin for error at all times. Avoid making sharp turns at speed, particularly in a short seaway.
 Caution	It is strongly recommended that helmsmen receive adequate training in boat handling before setting to sea for the first time.
 Caution	Be aware that factors such as altitude, temperature, load, and bottom growth may affect performance.

## 6.3 Visibility from the Main Steering Position



The international regulations for preventing collisions at sea (COLREG's) and the rules of the road require that a proper lookout be maintained at all times and observance of right of way. Make certain no other vessels are in the path before proceeding.

## 6.4 Navigation Lights

Information Night boating requires running lights. The craft is fitted with the following navigation lights:

Light	Mounting position
Port	Pushpit rail
Stbd	Pushpit rail
All-round red	0
All-round green	0
Tri-colour	Top of mast (optional)
Stern	Stbd side of pushpit
Anchor	Top of mast
Steaming	Front of mast



The running/navigation lights are controlled at the switch board.

	Caution	Check for proper operation of navigation lights before heading out and carry replacement bulbs for all navigation lights
	Caution	Navigation lights may be marked with expiry dates. Ensure that they are replaced as required.
	Caution	Always replace bulbs with one of the same wattage.

## 6.5 Anchoring, Mooring & Towing



**Information** It is the owners / operators responsibility to ensure that the mooring lines, towing lines, anchor chains, and anchors are adequate for the vessel's intended use. Owners should also consider what action will be necessary when securing a tow line on board.

Breaking strength of forward strong point: 69,4 kN = 7,1 tonnesf = 7072 kg

	Caution	The breaking strength of lines / chains should not exceed 80% of the breaking strength of the strong point to which it is attached.
	Caution	Always tow or be towed at slow speed. Never exceed the hull speed of a displacement craft when towing or being towed.
	Caution	A tow line shall always be made fast in a way that it can be released when under load.

**Information** When at anchor, it is damaging to leave the full load of the boat resting on the windlass. It is recommended that the chain be tied onto a local strong point.

## 6.6 Filling With Fuel

 <p>Caution</p>	<p>Never smoke when refuelling, or inspecting or working with the fuel system.</p>
<p>Information</p>	<p>For locations of filler caps, see: 3.2.4</p> <p>Use the following procedure for filling tanks:</p> <ul style="list-style-type: none"> <li>• Splash water over the deck-area around the filler cap - before filling. This will prevent spilled fuel from adhering to the deck surface</li> <li>• Open the filler cap &amp; start filling the tank.</li> <li>• Check the contents of the tank by monitoring the tank level indicator</li> <li>• Don't fill the tank to its maximum: allow for expansion</li> <li>• Close deck fittings tightly, but don't over-tighten since this will damage the rubber o-rings</li> <li>• (make an entry in ship's log)</li> </ul>
 <p>Caution</p>	<p>Fuel is considered chemical waste. Keep an absorbing cloth close by when filling tanks.</p>



# 7 MAINTENANCE

Regular inspection and maintenance is an essential activity to ensure the boat's longevity and the crew's safety.

	Warning	The outer skin of your boat is not designed to resist local damage from hitting hard or sharp objects. If the outer skin is damaged, it shall be repaired immediately.
---	---------	--

This section includes a generic table which details typical inspection and maintenance intervals. This is not specific to your craft and some sections will not apply.

The necessary frequency of service or maintenance depends upon the environment in which the boat operates. The intervals listed in this section should be viewed as maximums.

	Caution	Modifications that may affect the safety characteristics of the craft should be assessed, executed and documented by competent people.
	Caution	Any change in the disposition of the masses aboard may significantly affect the stability, trim and performance of the boat



**KEY:**            **X - Activity required**    **Y - Activity required by qualified individual**

Item	Required Maintenance/Service	INTERVAL				
		Before Every Use	After First 20 Hours	Every 25* Or 50 Hours	Every 50* Or 100 Hours	Every 6 mnth or Annual
<b>Miscellaneous</b>						
Battery	Check water level	X	X	X		
Navigation Lights	Check working	X				
Bilge Area	Clean & limber holes free					X
Bilge Blowers	Hose connections tight			X		X
Bilge Pumps	Float switch operates freely					X
Bilge drain plug	Installed and tight	X				
Zinc anodes	Check and replace	As needed				
Hull	Check for loose, damaged or missing parts	Whenever out of the water and always after striking an object				
<b>Controls</b>						
Steering	Check for proper operation					Y
Throttle	Lubricate. Include all shift linkage and pivot points		X		X	X
<b>Electrical</b>						
Connections	Check for looseness					Y
GFCI (AC) Outlet	Check operation			X		X



Engine						
Alarm	Check	X				
Cooling System	Check for leaks with engine running	X				
Crank vent system	Clean		X		X	
Drive belts	Check for wear	X				
Flame Arrestor	Clean		X		X	
Fuel Filter	Replace				X	
Mounts (Fasteners)	Tighten		X			X
Oil and Filter	Replace				X	X
Oil Level	Check	X				
Propeller	Inspect for damage	Always after striking object				
Fuel System						
Connections & Lines	Check for leaks & wear	X	X	X		
Tanks	Check for leaks & tightness of connections	X	X	X		
Water Separator	Replace		X			X
Exterior						
Topside & Supplies	Check for loose, damaged or missing parts					X
Gearbox						
Fluid level	Check level	X				
Fluid	Replace					X
Transmission						
Oil Strainer Screen	Clean					Y

## 7.1 Maintaining the Electrical System

 <p>Warning</p>	<p>Work on electrical wiring can create shock hazards or sparks.</p>
<p>Always disconnect power sources and shut off battery switch, breakers and/or pull fuses before checking electrical wiring or connectors.</p>	
 <p>Caution</p>	<p>To prevent arcing or damage to the alternator, always disconnect battery cables before doing any work on the engine's electrical system.</p>
 <p>Caution</p>	<p>Power feeds for accessory equipment must not be taken from the voltmeter terminals.</p>
<p>Information</p>	<p>Check all wiring for proper support.                  Check all wiring insulation for signs of fraying or chafing.</p> <p>Check all terminals for corrosion - corroded terminals and connectors should be replaced or thoroughly cleaned.</p> <p>Tighten all terminals securely and spray them with light marine preservative oil.</p>

## 7.2 Winter Storage

Your boat and the systems and fittings on board can be damaged if they are not properly prepared for the winter.

You should refer to the advice given in the various handbooks supplied with this manual.

In addition to this you should, for example, consider the following:

- Disconnect any gas bottles and place them in safe storage
- Fill the diesel tanks to reduce the effects of condensation
- Remove, charge and store the batteries in a warm & dry ventilated place
- Grease the appropriate steering gear components
- Drain non-fuel tanks
- Drain toilet bowls
- Ensure the engine cooling water has the correct proportion of anti-freeze
- Take away any removable delicate on board electrics and electronics
- Check and protect all the systems on the boat
- Remove all water from the craft and protect it from rain
- Ensure deck drains are clear
- Check the sacrificial anodes and replace as necessary

## 8 ENVIRONMENTAL AWARENESS

The previous sections of this manual provide information on how to protect the boat and its crew from the environment. This section gives information on how the environment may be protected from the boat and its crew.

The environment should be understood as including one's neighbours as well as the world of plants and animals.

In many regions of the world, there are strictly enforced regulations regarding environmental protection. It is the responsibility of the owner/operator to be aware of applicable regulations and to ensure compliance with them.

### 8.1 Leakage of Petrochemicals

	Warning	Any oil must be treated as chemical waste.
---	---------	--

**ALWAYS:** Investigate the source of any oil leaks as soon as possible.

Dispose of recovered spilt oil correctly.

Have oil-absorbing cloths or rolls on board.

**NEVER:** Dispose overboard of any oil, paint or other chemical that is potentially harmful to the environment. Sanctions are in place in most parts of the world for those who disregard this rule!

### 8.2 Black & Grey Water

	Warning	The discharge of effluent into navigable waters is forbidden by law in many areas. If such discharge causes a film or sheen upon or a discoloration of the surface of the water or causes a sludge or emulsion beneath the surface of the water, violators may be subject to a penalty. It is the responsibility of the boat user to ensure that they are aware of local legislation regarding discharge
---	---------	--

### 8.3 Household Waste

	Warning	When at sea for periods longer than space allows onboard storage of waste, only jettison organic waste.
---	---------	---

ALWAYS Retain any household waste until it can be properly disposed of ashore.

### 8.4 Noise

NEVER Make excessive noise. Most people take to the water for relaxation which is ruined by noise.  
Run the engine or generator unnecessarily.

### 8.5 Wash / Waves

ALWAYS Adapt your speed to the water in which you are navigating. Consider the comfort and safety of other (particularly small) boats around you.

	Warning	Be aware that in some areas speed restrictions are in place to avoid erosion of banks/coastline.
--	---------	--